

MODEL BA

BELT ALIGNMENT CONTROL PREVENTS CONVEYOR BELT RUN-OFF



- *Inexpensive protection for conveyor belts.*
- *Easy to install. Can be bolted directly to discharge chute or mounted to conveyor frame.*
- *Stainless ball bearings, spring, and pivot.*
- *UL and CSA listed switches: weather tight or explosion proof.*
- *Rugged and durable — not a light duty “whisker” switch.*

Model BA conveyor belt alignment control protects valuable conveyor belts from severe damage due to belt misalignment or run-off. The Model BA makes sure that the belts are tracking properly — prevents costly down time and unnecessary maintenance expense. Designed especially for bulk handling conveyor applications, it maintains a safeguard over equipment and keeps conveyor belts running.

Sometimes called a “side slip switch” or a “belt misalignment switch,” the Model BA operates on a very simple principal. Two controls are positioned close to the belt, one on each side, so that undesirable side to side motion of the belt will contact a switch roller. The roller “gives” just enough to actuate the switch. The signal generated by the actuated switch can be used to take appropriate action to re-align the conveyor belt, thus eliminating conveyor damage and serious down time.

CONSTRUCTION AND OPERATION

The Model BA belt alignment control has two basic welded steel components — the base housing and the roller housing. The roller housing contains the sensing roller and is attached to the base housing with a stainless steel pivot. The stainless steel pivot assures that movement will not be inhibited by corrosion. The roller and roller housing together are designed to pivot slightly when the roller is touched by the conveyor belt. The roller housing assembly actuates an enclosed switch mounted at the bottom of the base housing, it moves approximately 1/4” to actuate the switch. A stainless steel spring is mounted with a bolt at the bottom of the roller assembly to hold it away from the control except during actuation.

Microswitches are housed in either the standard weather tight, or optional explosion proof enclosures.

The roller has stainless steel ball bearings and nylon labyrinth seals to prevent corrosion and entry of water or dirt.

OPTIONAL BREAKAWAY MOUNT

This optional feature allows the Model BA to give a signal, and then to get out of the way if the belt does run-off, preventing serious damage to switches and belts. The breakaway mount is spring loaded and automatically returns the Model BA to its original position when the conveyor belt is realigned. It is designed so that the Model BA roller assumes a horizontal position when the breakaway mounting is actuated.

The breakaway mount is available with an optional switch to indicate that the breakaway condition has occurred. Thus, two signal can be generated: First, a signal from Model BA unit that the belt has deviated. Second, a signal from the breakaway switch that the belt has deviated further.



BA-55

NUMBER OF UNITS RECOMMENDED

Not less than four alignment switches shall be furnished on each conveyor. One on each side of the belt near the head and tail pulleys. For conveyors greater than 1,500 feet (457 meters) long an additional four alignment switches shall be provided evenly space, one on each side of the carrying and return belt.



Shown are two BA units protecting a valuable conveyor belt from damage due to belt misalignment or run-off at an aggregate facility

MODEL BA TECHNICAL INFORMATION

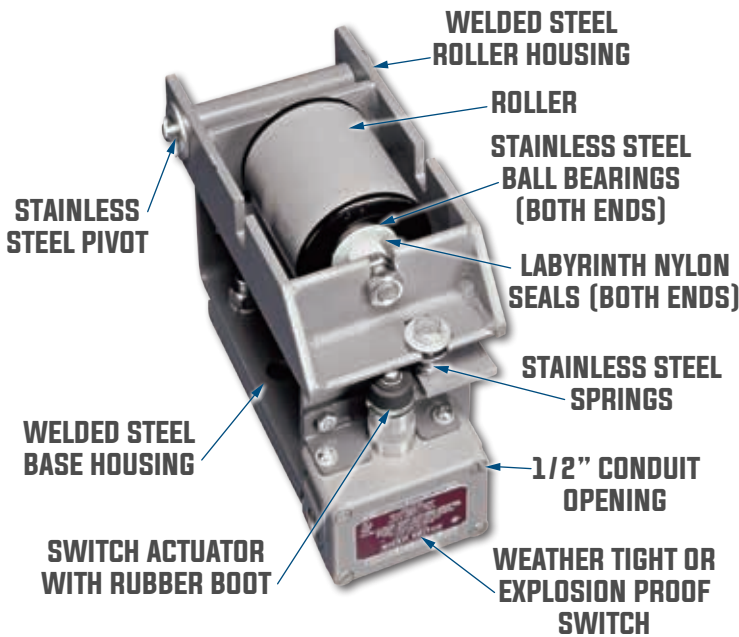

INSTALLATION INSTRUCTIONS

Model BA units are always used in pairs with one placed on each side of the conveyor belt, usually near the head end of the conveyor. They may also be placed at the tail pulley and at selected points along the conveyor.

The unit should be mounted on supports so that the roller is positioned in a vertical direction to intercept the conveyor belt at its mid-point. The roller is 3-1/2" high. The point of interception would be at the 1-3/4" point. Units should not be mounted too close to the belt because false signals would result. In most applications, the units could be mounted about 1" from the belt, eliminating false signals but protecting the belt against wide deviations.

The microswitch can be wired to give warning signals or it can be connected directly into the motor starter circuit to stop a conveyor. The roller moves approximately 1/4" to actuate the microswitch.

MODELS

| MODEL | SWITCH DESCRIPTION | ELECTRICAL RATING (BELOW) | SWITCH ENCLOSURE LISTING CLASSIFICATIONS: UL & CSA |
|-------|-------------------------------------|---------------------------|--|
| BA-1 | SP/DT, 20 Amp, Dust & Weather Tight | 1 | NEMA 1, 3, 4, 13 |
| BA-1X | SP/DT, 10 Amp, Explosion Proof | 3 | NEMA 7: Class I, Groups C & D NEMA 9: Class II, Groups E, F, & G |
| BA-2 | DP/DT, 10 Amp, Dust & Weather Tight | 2 | NEMA 1, 3, 4, 13 |
| BA-2X | DP/DT, 10 AMP, Explosion Proof | 2 | NEMA 7: Class I, Groups B, C & D NEMA 9: Class II, Groups E, F, & G |

OPTIONAL BREAKAWAY MOUNTING

| PART NUMBER | DESCRIPTION |
|-------------|---|
| BA-5 | Standard Break Away Mounting — No microswitch |
| BA-55 | SP/DT microswitch, 10 Amp, NEMA 1, 3, 4, 6, 13 |
| BA-55X | SP/DT microswitch, 10 Amp, Explosion Proof; NEMA 7 & 9 Also NEMA 1, 3, 4, 6, 13 |

*BA Belt Alignment Control purchased separately

SWITCH ELECTRICAL RATINGS

- 20 Amp @ 125, 250, or 480 VAC; 10 Amp @ 125 VAC "L"; 1 HP @ 125 VAC; 2HP @ 250 VAC; 1/2 Amp @ 125 VDC; 1/4 Amp @ 250 VDC.
- 10 Amp @ 125 or 250 VAC; 0.3 Amp @ 125 VDC; 0.15 Amp @ 250 VDC
- 10 Amp @ 125, 250 or 480 VAC; 1/2 Amp @ 125 VDC; 1/4 Amp @ 250 VDC.

